

Specifications

MODELS	SLC™-12		SLC™-18		SLC™-24	
MEASUREMENTS	US	Metric	US	Metric	US	Metric
Working height:						
standard forks - forks up	12 ft 11 in	3.94 m	18 ft 6 in	5.64 m	24 ft	7.32 m
standard forks - forks down	11 ft 2 in	3.40 m	16 ft 9 in	5.10 m	22 ft 3 in	6.78 m
adjustable forks - forks up	12 ft 11 in	3.94 m	18 ft 6 in	5.64 m	24 ft	7.32 m
adjustable forks - forks down	11 ft 2 in	3.40 m	16 ft 9 in	5.10 m	22 ft 3 in	6.78 m
boom**	12 ft 2 in	3.70 m	17 ft 9 in	5.41 m	23 ft 3 in	7.10 m
A Height - stowed	7 ft 2 in	2.18 m	7 ft 2 in	2.18 m	7 ft 2 in	2.18 m
B Length - stowed	2 ft 10 in	.86 m	2 ft 10 in	.86 m	2 ft 10 in	.86 m
C - operating	5 ft 3 in	1.60 m	6 ft 1 in	1.85 m	6 ft 9 in	2.06 m
D Width - stowed*	2 ft 7.5 in	.80 m	2 ft 7.5 in	.80 m	2 ft 7.5 in	.80 m
- with stabilizers lowered	5 ft 6 in	1.68 m	5 ft 6 in	1.68 m	5 ft 6 in	1.68 m

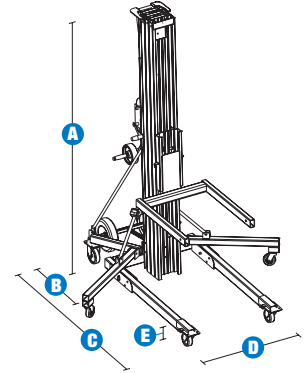

PRODUCTIVITY

Load capacity:						
1 ft 2 in (.36 m) load center	650 lbs	295 kg	650 lbs	295 kg	650 lbs	295 kg
2 ft (.61 m) load center	425 lbs	193 kg	425 lbs	193 kg	425 lbs	193 kg
3 ft 6 in (1.07 m) load center	180 lbs	82 kg	160 lbs	73 kg	160 lbs	73 kg
D Ground clearance	2 in	.05 m	2 in	.05 m	2 in	.05 m
Load height minimum	6 in	.15 m	6 in	.15 m	6 in	.15 m

POWER

Average cranks:						
standard winch	8.5 cranks/ft	27.8 cranks/m	8.5 cranks/ft	27.8 cranks/m	8.5 cranks/ft	27.8 cranks/m
two speed winch, high	4 cranks/ft	13.1 cranks/m	4 cranks/ft	13.1 cranks/m	4 cranks/ft	13.1 cranks/m
two speed winch, low	15 cranks/ft	49.2 cranks/m	15 cranks/ft	49.2 cranks/m	15 cranks/ft	49.2 cranks/m

WEIGHT

	204 lbs	93 kg	307 lbs	139 kg	374 lbs	170 kg
--	---------	-------	---------	--------	---------	--------

LOAD HANDLING ATTACHMENTS

MEASUREMENTS	US	Metric	Weight - US	Weight - Metric
Standard forks (l/w/d)	28/23/2.5 in	71/58/6 cm	26.5 lbs.	12 kg
Adjustable forks (l/w/d)	27.5/11-30/2.5 in	70/28-76/6 cm	52.5 lbs.	24 kg
Fork extensions (each) (l/w/d)	30/2/3 in	76/5/8 cm	4.5 lbs	2 kg
Boom (l/w/d)	18-42/1.5/6 in	46-107/4/15 cm	34.5 lbs	16 kg
Pipe cradle*** (l/w/d)	27.5/24/6 in	70/61/15 cm	10 lbs	4.5 kg
Load platform (l/w/d)	26.25/23/2.5 in	67/58/6 cm	26.5 lbs	12 kg

* Outside dimensions.

** Measured from ground to bottom of shackle.

*** Handles round objects up to 30 in (76 cm) in diameter.

Features

EASILY CONFIGURED TO MEET YOUR NEEDS

PLATFORM OPTIONS

- Boom
- Standard forks
- Adjustable forks
- Fork extensions
- Pipe cradle
- Load platform

POWER OPTIONS

- One speed winch
- Two speed winch

BASE OPTIONS

- Standard base
- Stabilizer set

CASTER OPTIONS

- 4 in (10 cm) front casters
- 5 in (13 cm) rear casters with side brakes
- Fixed front caster option

STANDARD FEATURES

MEASUREMENTS

SLC™-12

- 12 ft 11 in (3.94 m) working height
- Up to 650 lb (295 kg) lift capacity

SLC™-18

- 18 ft 6 in (5.64 m) working height
- Up to 650 lb (295 kg) lift capacity

SLC™-24

- 24 ft (7.32 m) working height
- Up to 650 lb (295 kg) lift capacity

PRODUCTIVITY

- Standard forks
- Heavy-duty design
- Strong, lightweight aluminum telescoping mast
- Single door access
- Quick set up requires no tools
- Interchangeable load handling attachments
- Non-marking 4 in (10 cm) front casters and 5 in (13 cm) rear casters with side brakes
- Rear transport wheel assembly
- Glide rails allow easy loading and unloading, on or off a vehicle, for transport
- Hold-down bar secures mast assembly during transport
- Stabilizer set (standard on SLC™-18, -24)

POWER

- One speed winch



OPTIONS & ACCESSORIES

PRODUCTIVITY

- Boom
- Adjustable forks
- Fork extensions
- Pipe cradle
- Load platform
- Fixed front casters
- Stabilizer set (option on SLC™-12)

POWER

- Two speed winch

Genie United States

18340 NE 76th Street
P.O. Box 97030
Redmond, Washington 98073-9730

Telephone **(425) 881-1800**
Toll Free in USA/Canada **800-536-1800**
Fax (425) 883-3475

Genie Europe

The Maltings
Wharf Road
Grantham NG31 6BH
U.K.

Telephone **+44 (0)1476 584333**
Fax +44 (0)1476 584334

Email: infoeurope@genieind.com

Distributed By:

For further information, please contact your local distributor or the Genie Industries sales office listed. Continuous improvement of our products is a Genie policy. Product specifications are subject to change without notice or obligation. The photographs and drawings in this brochure are for illustrative purposes only. Refer to the appropriate Operator's Manual for instructions on the proper use of this equipment. Failure to follow the appropriate Operator's Manual when using our equipment or to otherwise act irresponsibly may result in serious injury or death. Prices and specifications subject to change without notice. The only warranty applicable is the standard written warranty applicable to the particular product and sale. Genie makes no other warranty, expressed or implied. Products and services listed may be trademarks, service marks or trade-names of TEREX Corporation and/or its subsidiaries in the USA and other countries and all rights are reserved. Copyright © 2005 Genie Industries, Inc. "Genie" is a Registered Trademark of Genie Industries, Inc. in the USA and many other countries. Genie is a TEREX Company.