

Standards Compliance

- ANSI A92.6
- CSA B354.2
- CE Compliance
- AS 1418.10

Specifications

Genie United States

18340 NE 76th Street
P.O. Box 97030
Redmond, Washington 98073-9730

Telephone **(425) 881-1800**
Toll Free in USA/Canada **800-536-1800**
Fax (425) 883-3475

Genie Europe

The Maltings
Wharf Road
Grantham NG31 6BH
U.K.

Telephone **+44 (0)1476 584333**
Fax +44 (0)1476 584334
Email: infoeurope@genieind.com

www.genieindustries.com

Distributed By:

For further information, please contact your local distributor or the Genie Industries sales office listed. Continuous improvement of our products is a Genie policy. Product specifications are subject to change without notice or obligation. The photographs and drawings in this brochure are for illustrative purposes only. Refer to the appropriate Operator's Manual for instructions on the proper use of this equipment. Failure to follow the appropriate Operator's Manual when using our equipment, or to otherwise act irresponsibly, may result in serious injury or death. Prices and specifications subject to change without notice. The only warranty applicable is the standard written warranty applicable to the particular product and sale. Genie makes no other warranty, expressed or implied. Products and services listed may be trademarks, service marks or trade-names of TEREX Corporation and/or its subsidiaries in the USA and other countries and all rights are reserved. Copyright © 2005 Genie Industries, Inc. "Genie" is a Registered Trademark of Genie Industries, Inc. in the USA and many other countries. Genie is a TEREX Company. GS4390 3.5K 0305A. Part No. 109355

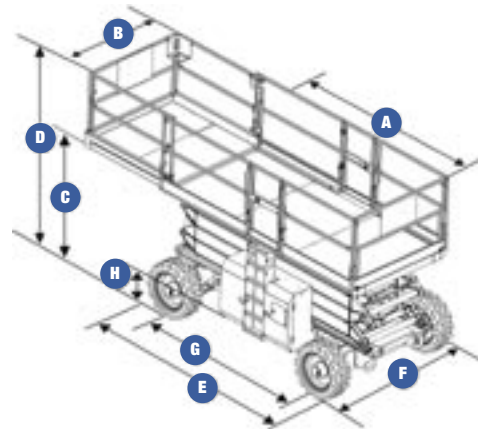

GS™-4390 RT

	US	Metric
--	-----------	---------------

MEASUREMENTS:

Working height max*	49 ft	15.1 m
Platform height max	43 ft	13.1 m
A Platform length - outside - extended		
- single deck	17 ft 6.25 in	5.3 m
- dual deck	21 ft 6.5 in	6.6 m
- super deck	24 ft 2.5 in	7.4 m
B Platform width - outside	6 ft	1.83 m
C Platform height - stowed**	5 ft 11 in	1.8 m
D Height		
-stowed	9 ft 7.5 in	2.9 m
-rails lowered	7 ft 4.75 in	2.3 m
E Length - stowed		
- single deck	12 ft 11.25 in	3.9 m
- dual deck	13 ft 5 in	4.0 m
- with outriggers	16 ft	4.9 m
F Width: standard tires	7 ft 6 in	2.3 m
Width: high flotation tires	8 ft 5 in	2.6 m
G Wheelbase	9 ft 4 in	2.8 m
H Ground clearance	1 ft 2 in	.36 m
Lift capacity	1,500 lbs	680 kg
Lift capacity - extension deck	500 lbs	227 kg

PRODUCTIVITY:

Drive speed - stowed	5.0 mph	8 km/h
Drive speed - raised	0.7 mph	1.1 km/h
Gradeability***	50%	50%
Turning radius - inside	7 ft 1 in	2.2 m
Turning radius - outside	17 ft 6 in	5.3 m
Controls	proportional	proportional
Raise / lower speed	45 / 39 sec	45 / 39 sec
Tires - solid non-marking	12 - 21.5 NHS foam-filled	12 - 21.5 NHS foam-filled

POWER:

Power source	Ford gas/LPG 82 hp (61 kW)	Deutz diesel F3L 1011 49 hp (36 kW), air cooled
Fuel tank capacity	30 gal	113.6 L
Hydraulic tank capacity	30 gal	113.6 L
Weight****	13,086 lbs	5,936 kg

*The metric equivalent of working height adds 2 m to platform height. U.S. adds 6 ft to platform height.

** Based on RT tires. Deduct 2.0 in (5.8 cm) for turf and non-marking tires.

***Gradeability applies to driving on slopes. See operators manual for details regarding slope ratings.

****Weight will vary depending on options and/or country standards.

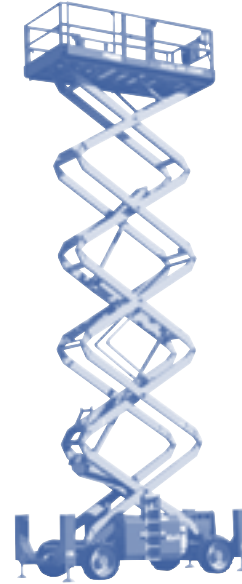

Easily Configured to Meet Your Needs:

PLATFORM OPTIONS

- Dual slide-out extension deck package 5 ft (1.5 m) front and 4 ft (1.2 m) rear
- Super deck (outriggers required)

POWER OPTIONS

- Ford gas/LPG 86 hp (61 kW)
- Deutz diesel 49 hp (36 kW)

DRIVE OPTION

- 4WD

TIRE OPTIONS

- Foam-filled rough terrain tires
- High flotation air-filled tires
- Non-marking tires

Standard Features

MEASUREMENTS:

- GS™-4390 RT has 49 ft (15.1 m) working height
- Up to 1,500 lbs (680 kg) lift capacity

POWER:

- Meets current emissions standards

PRODUCTIVITY:

- 5 ft (1.5 m) slide-out extension deck
- Diamond plate deck
- Proportional lift and drive
- On-board diagnostic system
- AC power to platform
- Two self-closing gates
- Electric horn
- Tilt sensor with audible alarm
- Descent alarm
- Hour meter
- Full-time positive traction control
- Four-wheel drive
- Slide-out engine tray
- Foam-filled rough terrain tires

Options and Accessories

PRODUCTIVITY

- Dual slide-out extension deck package
- Automatic leveling hydraulic outriggers
- Air line to platform
- Platform work lights
- Pipe cradle (pair)
- Dual flashing beacons
- Motion alarm
- Oscillating axle

POWER:

- 2000 watt generator (110 V / 60 Hz)
- Cold start packages for all engines
- Diesel scrubber/spark arrestor
- Diesel spark arrestor (without scrubber)
- Hydraulic oil cooler
- LPG steel tank only, 33.5 lb capacity
- LPG tank kit (carrier with tank)